

INVERTER VERTICAL TURNING TYPE

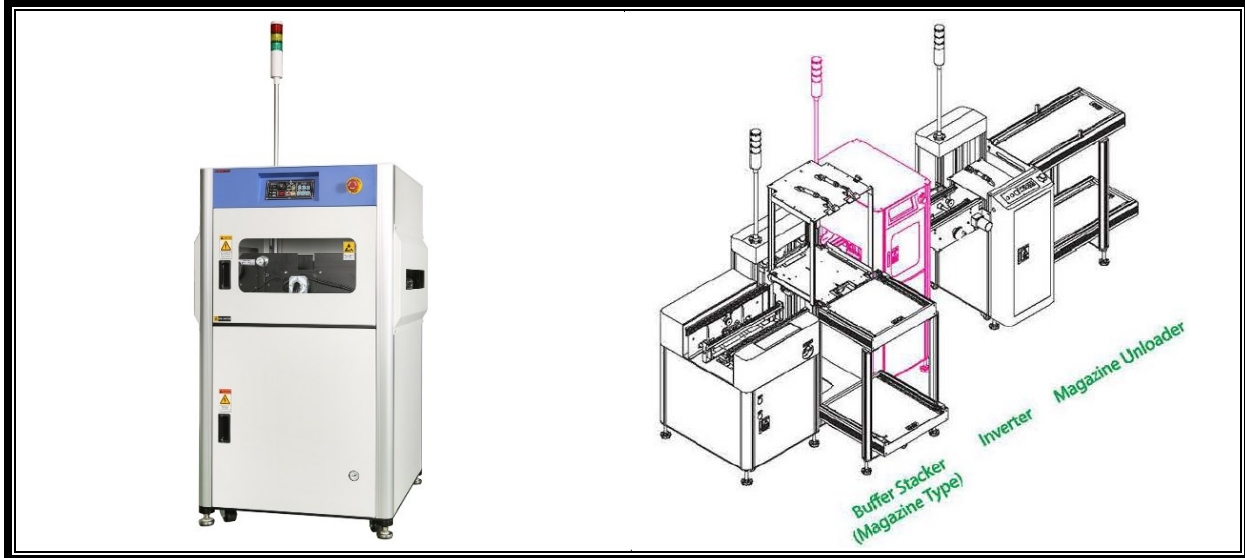

FEATURES

- SMEMA Interface
- Durable structure with double base plate
- Shock absorber for PCB holding
- Safe inverting system with double cylinder
- Safety full cover
- Smooth and precise inverting motion
- 3 color LED light tower
- Buzzer
- Touchscreen
- 3mm edge clearance at conveyor
- Clearance (upper – 25mm / lower – 25mm) at conveyor with pass mode

OPTIONS

- Conveyor automatic width adjustment
- Conveyor speed control
- Dual lane
- CE
- RS-485 communication

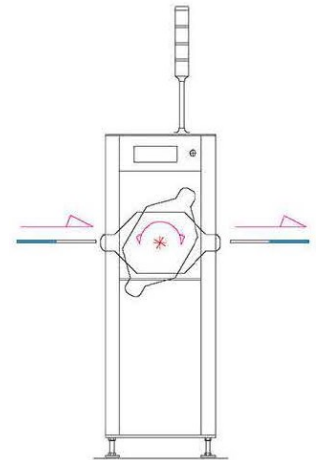

SPECIFICATIONS

Model	Type	Max. PCB (L x W) mm	Min. PCB (L x W) mm	Dimension (L x W x H)	Power	Air (MPa)	Weight (Kg)
AVT-50S	S	330 x 250	50 x 50	500 x 640 x 1355	0.3kVA	0.5 ± 0.1	170
AVT-50Y	Y	440 x 330		610 x 720 x 1355			180
AVT-50L	L	530 x 375		700 x 760 x 1355			190
AVT-50X	XL	530 x 460		700 x 760 x 1355			200
AVT-502X	2XL	610 x 460		800 x 850 x 1355			200

Custom options available by request