

SHUTTLE CONVEYOR

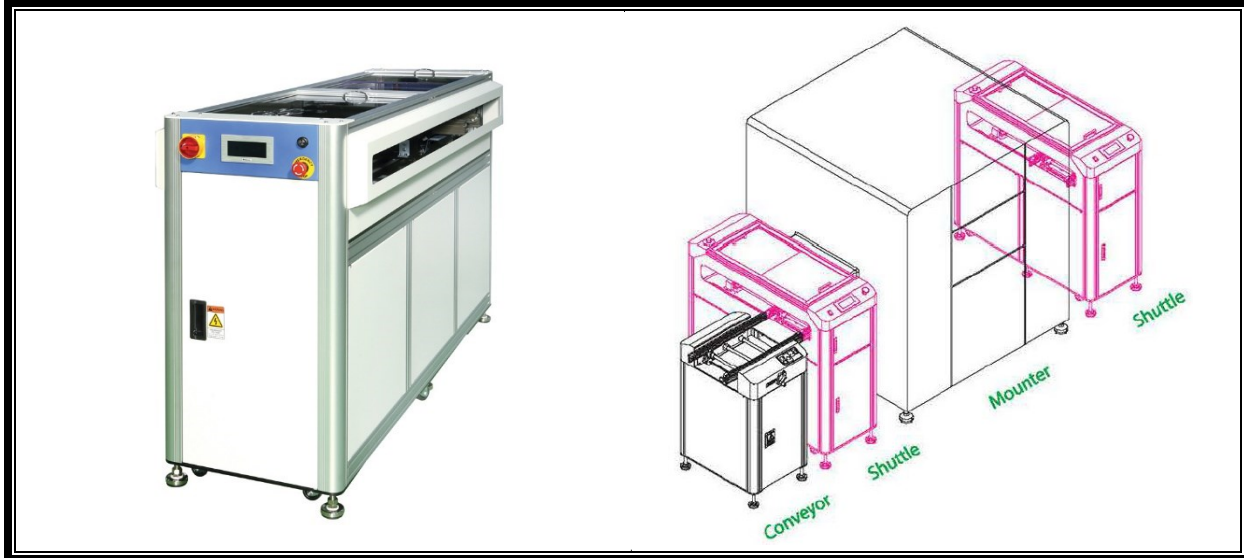

FEATURES

- SMEMA interface
- Touchscreen
- 1-IN/1-OUT, 1-IN/2-OUT, 2-IN/1-OUT, and 2-IN and 2-OUT
- Durable structure with double base Plate
- Buzzer
- Sliding system by servo motor
- Timing belt method
- 1 & 4 distance based on 686 mm
- Safety full cover
- 3mm edge clearance at conveyor
- Clearance (upper – 25mm / lower – 25mm) at conveyor

OPTIONS

- Conveyor automatic width adjustment
- Conveyor speed control
- Pneumatic stopper
- 3 colored LED light tower
- Dual lane
- CE
- RS-485 communication

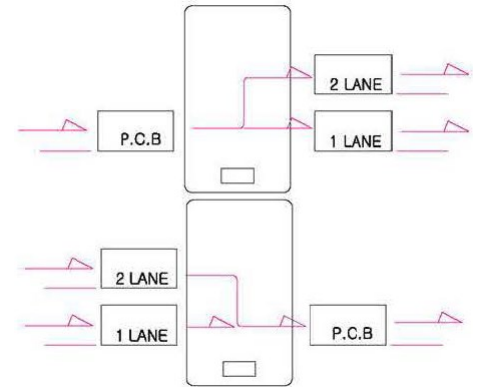

Model	Type	Max. PCB (L x W) mm	Min. PCB (L x W) mm	Dimension (L x W x H)	Power	Weight (Kg)
ASHC-50S	S	330 x 250	50 x 50	510 x 1240 x 1020	0.3kVA	180
ASHC-50Y	Y	440 x 330		510 x 1320 x 1020		190
ASHC-50L	L	530 x 375		610 x 1365 x 1020		200
ASHC-50X	XL	530 x 460		610 x 1450 x 1020		210
ASHC-502X	2XL	610 x 460		710 x 1450 x 1020		220

Custom options available by request