

WORKTABLE

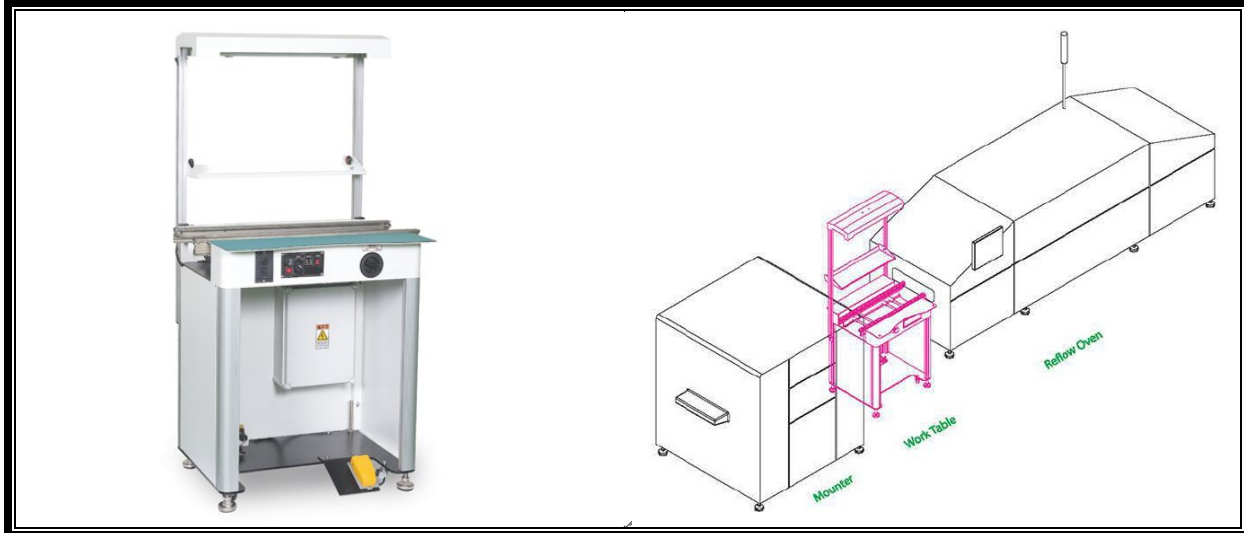

FEATURES

- SMEMA Interface
- Operator work space at the front
- LED lighting
- Work and pass mode
- Durable structure with double base plate
- Conveyor speed control
- Button operation
- Buzzer
- 3mm edge clearance at conveyor
- Clearance (upper – 25mm / lower – 25mm) at conveyor

OPTIONS

- Conveyor automatic width adjustment
- ESD cover at conveyor
- Cooling fan at conveyor
- Touchscreen
- Front door
- Pneumatic stopper
- Selectable rail length
- Multi-zone segment
- Selectable belt type (ESD, heat resistant, chain, etc.)
- 3 color LED light tower
- Dual lane
- CE

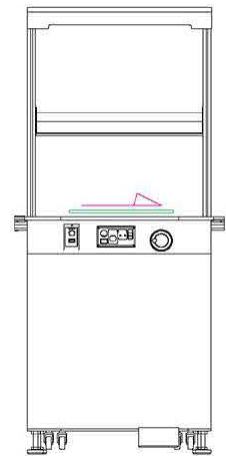

SPECIFICATIONS

Model	Type	Max. PCB (L x W) mm	Min. PCB (L x W) mm	Dimension (L x W x H)	Power	Weight (Kg)
AWT-80S	S	330 x 250	50 x 50	800 x 675 x 1700	0.2kVA	90
AWT-80Y	Y	440 x 330		800 x 755 x 1700		100
AWT-80L	L	530 x 375		800 x 800 x 1700		130
AWT-80X	XL	530 x 460		800 x 885 x 1700		140
AWT-802X	2XL	610 x 460		1000 x 884 x 1700		160

Custom options available by request